



**Special two layers harder face design**

To satisfied the right-angle retention requirements of work.

**VITRIFIED  
 CENTERLESS  
 GRINDING WHEELS**

Anchor Centerless Wheels are available in a range of specifications for high metal removal rates and optimum wheel life.



**■ CENTERLESS GRINDING**

**CENTERLESS GRINDING METHOD**

Centerless grinding differs from cylindrical grinding operations in that no spindle or fixture is used to locate and secure the work piece; the work piece is secured between a centerless grinding wheel and a regulating wheel.

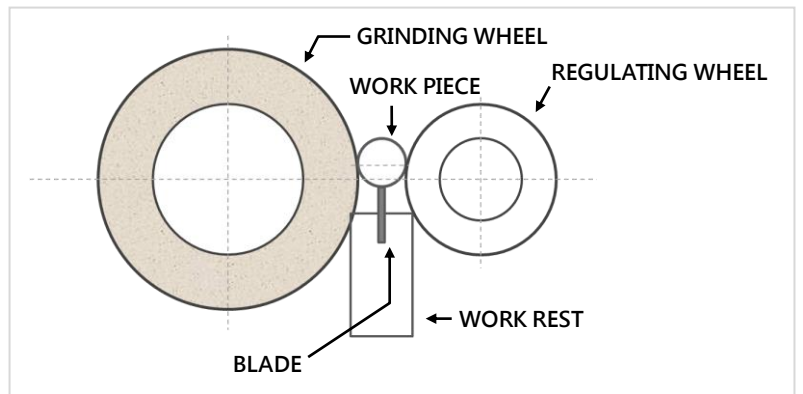

**REGULATING WHEELS and MACHINE TYPE**

Regulating wheels are always made by resin bond, the main function include:

- A. Control the feed rate and speed of work piece.
- B. Secure the work piece.
- C. Control the diameter of work piece.

Wheel and Regulating wheel size comparative table / Unit : mm

Grinding Wheel Size			Regulating Wheel Size		
Diameter	Thickness		Diameter	Thickness	
305	100	150 205	205	100	150 205
355	150	205	205	150	205
405	150	205	255	150	205
455	150	205 255 305	255	150	205 255 305
510	150	205 255 305	305	150	205 255 305
610	205	255 305	305	205	255 305

## SPICIFICATION

### ■ Standard size of centerless grinding ( unit : mm )

TYPE	SHAPE	SIZE						
		D	T	H	P	E	F	G
12"Centerless	7A	305	150	120	175	100	25	25
12"Regulating	7A	205	150	90	130	100	25	25
18" Centerless	7A	455	205	228.6	295	155	25	25
18" Regulating	7A	255	205	111.2	170	110	75	20
20" Centerless	7A	510	205	254	320	155	25	25
20" Regulating	7A	305	205	127	190	110	75	20
20" Centerless	7A	510	205	304.8	360	155	25	25
20" Regulating	7A	305	205	127	200	103	63.5	38.5

■ The standard shape and face 7A of centerless wheel.

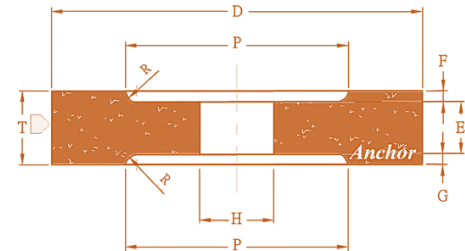

### ■ Regular specifications of centerless and regulating wheels

Material	Application	Specification
S09CK、S45C、SK1~7 SMn、SCr、SCM、SNCM SKS、SKD、SKT SUH 1、3、4 SKH SUJ2、SUJ3 Iron	Without special treatment softer hardness	<b>38A 60-80 L</b> WA 60-80 L A 60-80 L
	Heat treated with harder hardness or higher retention requirements	<b>50A 80-100 L</b>
	Two layers of harder face design to satisfied the right-angle retention requirements of work	<b>38A 80 LM/NO</b> <b>50A 80-100 LM/NO</b> 64A 80-100 M/O
SUS 300 400 FC FCMW、FCMB、FCMP Chrome plated Copper, aluminum, plastic, rubber and so on	Non-ferrous material	<b>GC 60-80 K</b> <b>GC 60-80 L</b>

■ Special two layers of harder face design for several specifications of 305mm and 455mm standard size.

■ For any further inquiry, please contact us via the company information below.

## COMPANY INFORMATION

## CARBO TZUJAN INDUSTRIAL CO., LTD.

- For details, please contact the following agency.

**Anchor<sup>®</sup>**

### INFORMATION:

- TEL : +886-2-2679-3461
- FAX : +886-2-2679-4561
- Head Office: 239 No.1 Fu An St. Ying Ko District, New Taipei City, Taiwan.

### CONTACT US:

- Online service : [www.carbo.com.tw](http://www.carbo.com.tw)
- E-mail : [webmaster@carbo.com.tw](mailto:webmaster@carbo.com.tw)

- While using grinding wheels, it is essential that you observe correct procedures to protect yourself.