

**Anchor** <sup>Since 1946</sup>

*Partner for ultimate success*

# CBN Resin Bond

HSS SAW BLADE GRINDING WHEEL



**Resin Bond HSS Saw Blade Grinding Wheels**

Reach the requirement of excellent cutting ability, long life time and perfect profile persistence. Provide the best solution for HSS Saw Blade Grinding.

■ **Wheels type for use on HSS Saw Blade**



**Grinding Wheels for HSS Saw Blade**

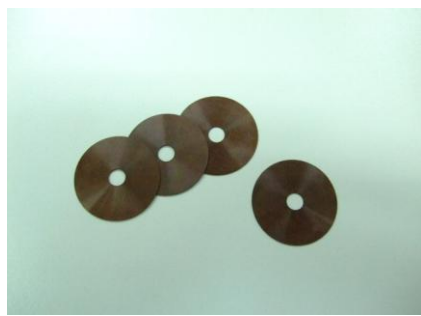

**Grooving Wheels for HSS Saw Blade**



**Grooving process of HSS Saw Blade**

■ **Material, Grinding Method and Shape**

Grinding Method	
Blade	
Regrinding	
Material	
SKH	
HRC63	

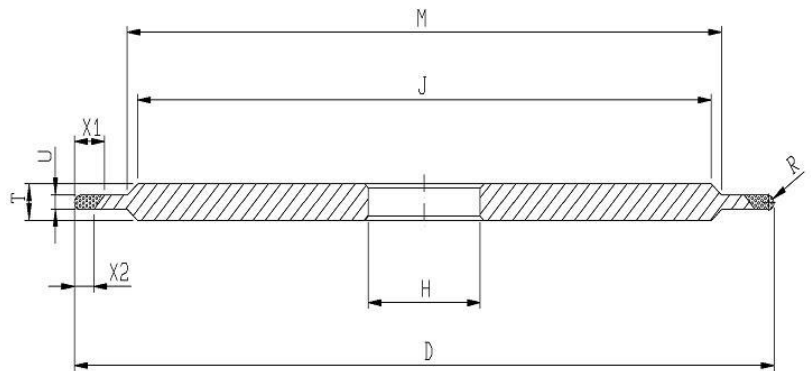

## SPECIFICATION

### ■ Regular Specification and Size / Unit: mm

Abrasive	Grit size	Hardness	Concentration	Bond	Shape
CBN	140	P	125	B	14F1
D	T	H	U	X	
150 200	8	32	Less than 1.3	5 / 7	
			1.3 ~ 3.0	6 / 8	
			3.0 ~ 5.0	8	
			6.0	10	

- Aluminum Basement for U size less than 2.0 mm.
- Steel Basement for U size more than 2.1 mm.

### ■ Regular Specification and Size for HSS Grooving / Unit: mm

Abrasive	Grit size	Hardness	Concentration	Bond	Shape
CBN	200	P	125	B	1A8
D	T	H			
30	0.3	6			
	0.375		8		
	0.4				

- For any further inquiry, please contact us via the company information below.

## COMPANY INFORMATION

## CARBO TZUJAN INDUSTRIAL CO., LTD.

- For details, please contact the following agency.

*Anchor*<sup>®</sup>

### INFORMATION:

- TEL : +886-2-2679-3461
- FAX : +886-2-2679-4561
- Head Office: 239 No.1 Fu An St. Ying Ko District, New Taipei City, Taiwan.

### CONTACT US:

- Online service : [www.carbo.com.tw](http://www.carbo.com.tw)
- E-mail : [webmaster@carbo.com.tw](mailto:webmaster@carbo.com.tw)

- While using grinding wheels, it is essential that you observe correct procedures and work safely to protect yourself.